

Rubber Seal

# Rotary Joint



- Oldham coupling
- Operating pressure range: **-100 kPa to 0.7 MPa**
- Allowable rpm: **200 min<sup>-1</sup>**<sup>\*1</sup>
- Max. start-up rotation torque: **0.50 N·m**<sup>\*2</sup> or less
- Service life: **10 million rotations**<sup>\*3</sup>
- Number of circuits: **8 circuits**

\*1 Reference value  
 \*2 When no pressure applied.  
 \*3 Under SMC's life test conditions.

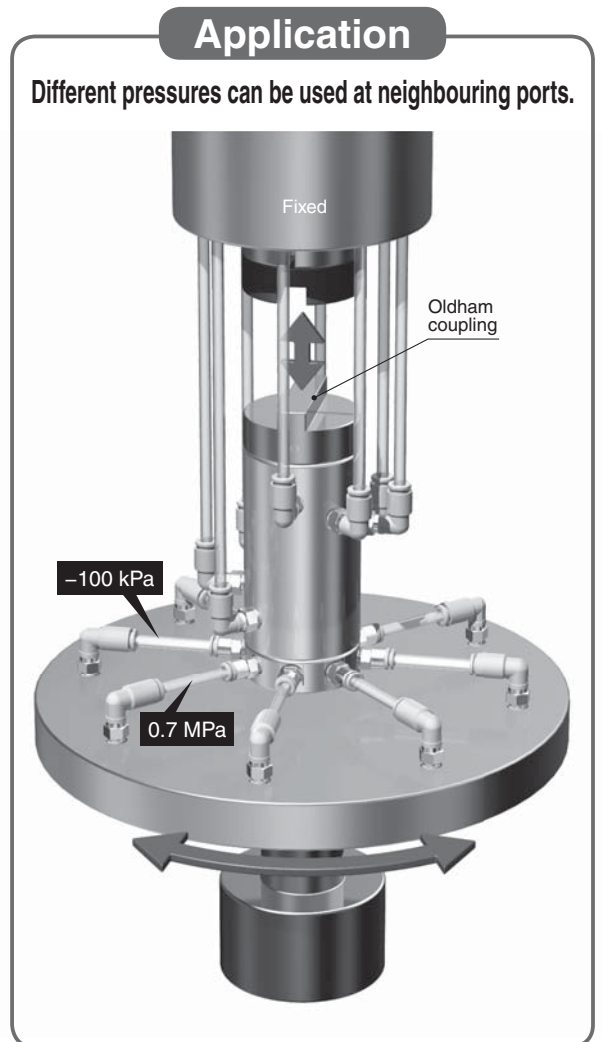

Related Equipment

## Low Torque Rotary Joint MQR Series

- Metal seal type
- Long service life\*

| Series      | Service life          | Series       | Service life          |
|-------------|-----------------------|--------------|-----------------------|
| <b>MQR1</b> | 1 billion rotations   | <b>MQR8</b>  | 0.2 billion rotations |
| <b>MQR2</b> | 0.5 billion rotations | <b>MQR12</b> | 0.1 billion rotations |
| <b>MQR4</b> | 0.3 billion rotations | <b>MQR16</b> | 0.1 billion rotations |

\* Under SMC's life test conditions.

- Max. start-up rotation torque: 0.003 to 0.50 N·m or less



# MQR-X229



Rubber Seal

# Rotary Joint

# MQR-X229

RoHS



## How to Order

MQR **F** 8 - M5 - X229

| Option |          |
|--------|----------|
| —      | Standard |
| F      | Flange   |

- Option
- Number of circuits
- Connection diameter: M5 x 0.8
- Rubber seal

## Option/Mounting Bracket

| Number of circuits | Flange part number |
|--------------------|--------------------|
| 8 circuits         | MQR8-F-X229        |

## Specifications

|                                                      |                               |                                        |
|------------------------------------------------------|-------------------------------|----------------------------------------|
| Number of circuits (Number of ports)                 |                               | 8 circuits                             |
| Fluid                                                |                               | Air                                    |
| Seal structure                                       |                               | Rubber seal                            |
| Guide structure                                      |                               | Bearing supported at both ends         |
| Flow-rate characteristics                            | C                             | 0.50 [dm <sup>3</sup> /(s·bar)]        |
|                                                      | b                             | 0.40                                   |
|                                                      | Cv                            | 0.17                                   |
|                                                      | Q                             | 136 [l/min (ANR)] <sup>Note 4)</sup>   |
| Lubrication                                          |                               | Not required                           |
| Minimum operating pressure                           |                               | -100 kPa (10 Torr)                     |
| Maximum operating pressure                           |                               | 0.7 MPa                                |
| Ambient temperature                                  |                               | 5 to +40 °C <sup>Note 1) Note 2)</sup> |
| Fluid temperature                                    |                               |                                        |
| Start-up torque (Reference value) <sup>Note 3)</sup> | When no pressure applied      | 0.5 N·m or less                        |
|                                                      | When 0.7 MPa pressure applied | 0.8 N·m or less                        |
| Allowable rpm (Reference value)                      |                               | 200 min <sup>-1</sup>                  |
| Weight                                               |                               | 0.53 kg                                |

Note 1) Temperature rise: 50 °C

<Conditions>

- Supply pressure: 0.7 MPa
- Rotation number: 200 min<sup>-1</sup>(rpm)

Example) When the ambient temperature is 20 °C, the surface temperature of the rotary joint is 70 °C.

Note 2) The surface temperature of the rotary joint should not be more than 80 °C. (Including the heat generated by adiabatic compression, etc.)

Note 3) The start-up torque may increase temporarily depending on the period of non-operation. For rotational torque with rotation number, refer to "Change in Rotational Torque with Rotation Number".

Note 4) This value has been calculated according to the ISO 6358 and represents the flow rate measured in standard conditions at an upstream pressure of 6 bar (relative pressure) and a differential of pressure of 1 bar.

## Construction

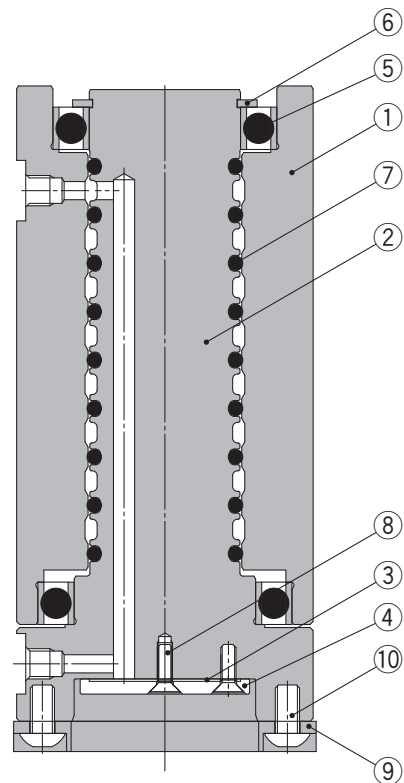

## Component Parts

| No. | Description    | Material        | Note                      |
|-----|----------------|-----------------|---------------------------|
| 1   | Body           | Aluminium       |                           |
| 2   | Spool          | Aluminium       |                           |
| 3   | Gasket         | H-NBR           |                           |
| 4   | Plate          | Stainless steel |                           |
| 5   | Radial bearing | —               |                           |
| 6   | Retaining ring | Carbon steel    |                           |
| 7   | O-ring         | Special NBR     | * Fluorine grease applied |
| 8   | Bolt           | Carbon steel    |                           |
| 9   | Flange         | Aluminium       | * Only for the MQRF8      |
| 10  | Bolt           | Carbon steel    |                           |

### Change in Rotational Torque with Rotation Number

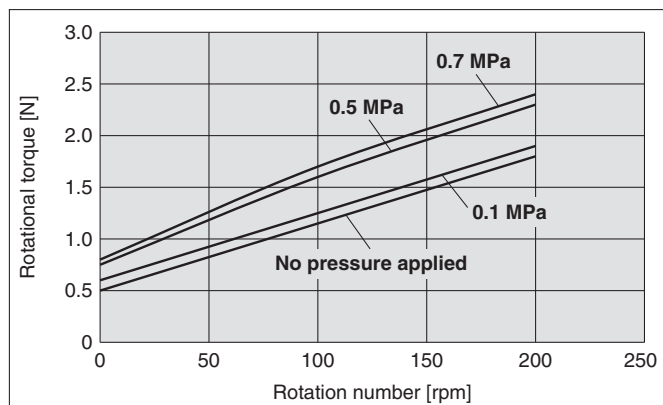

Note) These values show reference values and are not guaranteed.

### Dimensions

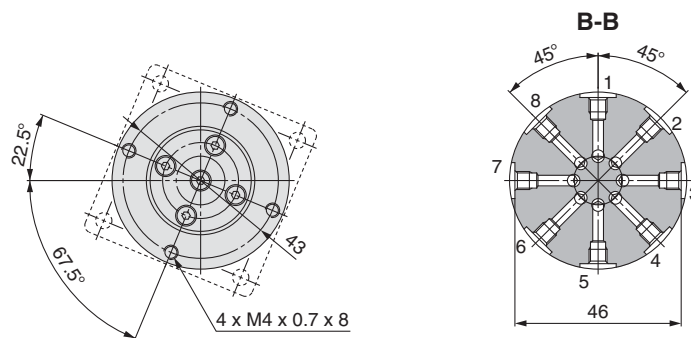

Note) Indicates flange dimensions.

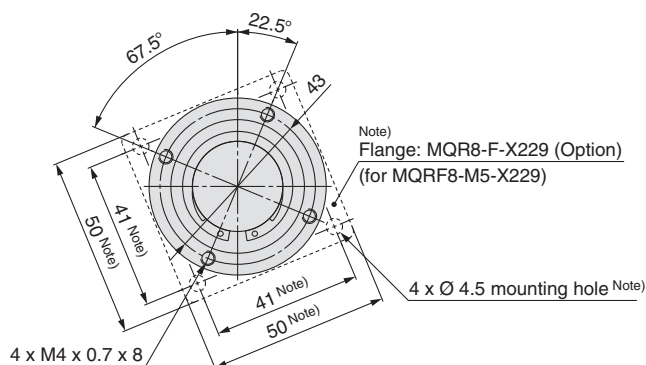
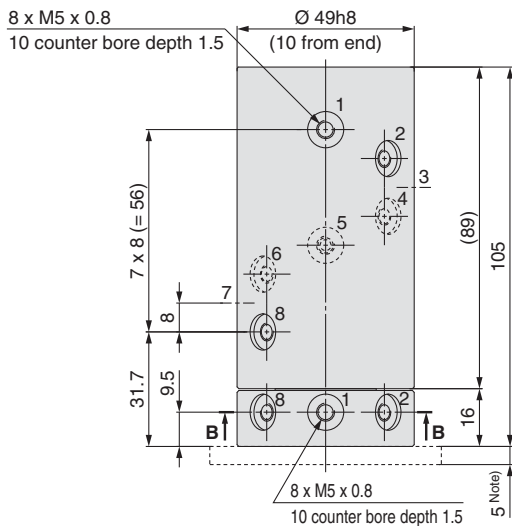



# MQR-X229

## Specific Product Precautions

Be sure to read this before handling. For Safety Instructions and Rotary Joint Precautions, refer to "Handling Precautions for SMC Products" and the Operation Manual on the SMC website, <http://www.smc.eu>

### Design

#### Warning

- 1. A protective cover is recommended to minimise the risk of human injury.**  
If a moving part poses a risk of human injury and/or damage to machinery/equipment, then a structure which prevents direct contact with that part should be adopted.
- 2. Securely tighten all stationary parts and connected parts so that they will not become loose.**  
Secure fastening is particularly important when the rotary joint has a high operating frequency.
- 3. Provide safety devices in drive circuit.**  
Collisions, or foreign material introduced by the air source, may cause scuffing or burning of rotating parts, which in turn leads to increased rotational torque. Install safety devices in the drive circuit accordingly.
- 4. Do not use in an emergency shutdown air circuit.**  
This product is not designed for use in a safety circuit performing emergency shutdown. Other reliable safety protection means should be adopted for such systems.
- 5. Ensure room for maintenance.**  
Leave sufficient space for maintenance work.
- 6. Releasing residual pressure.**  
Provide a residual pressure release function in order to carry out maintenance work.
- 7. Using vacuum supply.**  
When using a vacuum air supply, install a suction filter, or equivalent, to prevent infiltration of dirt and foreign material via the adsorption pad or exhaust port.
- 8. Do not disassemble the product or make any modifications, including additional machining.**  
It may cause human injury and/or an accident.
- 9. This product is not guaranteed for zero leakage.**  
It cannot be used for vacuum holding or pressure holding in pressure vessels, etc. Please consult with SMC for leakage amount.

### Selection

#### Warning

- 1. Confirm the specifications.**  
The product advertised in this catalogue is designed according to use in industrial compressed air systems. If the product is used in conditions where pressure, temperature, etc. are out of specification, damage and/or malfunction may be caused. Do not use in these conditions. (Refer to specifications.)
- 2. Do not use for power transmission.**  
This product is not designed to be used as bearings for transmitting power from a drive source, such as a motor. Such use may lead to rotation faults, or damage.

### Mounting

#### Warning

- 1. Allow freedom of movement when securing the shaft.**  
If you do not allow some freedom of movement when fixing the shaft, any eccentricity will cause abnormal wear, leading to malfunction, breakdown, and possible human injury and/or damage to machinery/equipment.

#### Caution

- 1. Confirm the model and size before installation. Check that there are no scratches, impact marks, cracks, or the like, on the product.**
- 2. When connecting tubes, take account of variations in pressure according to tube length.**
- 3. Do not use organic solvent to wipe the area of the name plate that shows the model.**  
It will erase what is indicated on the name plate.
- 4. Do not knock the rotary shaft when the main unit is fixed, or knock the main unit when the rotary shaft is fixed.**  
This may bend the rotary shaft and cause damage to the bearings. The rotary shaft should be fixed when attaching a load, etc. to it.
- 5. When the rotary joint is secured, align the axes using the slip fit of the body adapter plate.**
- 6. Implement the tube piping in such a way that lateral load is not applied to the ball bearings at the rotating part, otherwise it may adversely affect the life expectancy.**

### Piping

#### Caution

- 1. Preparation before piping**  
Before piping is connected, it should be thoroughly blown out with air (flushing), to remove chips, cutting oil and other debris from inside the piping.

### Piping

#### Caution

- 2. Wrapping of sealant tape**  
When screwing together pipes and fittings, etc., be certain that chips from the pipe threads and sealant material do not get inside the piping. Also, when sealant tape is used, leave approximately 2 thread ridges exposed at the end of the threads.
- 3. Screw tightening and tightening torque**  
Use the tightening torques in the table below, when screwing a fitting onto a piping port.

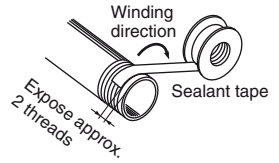

#### Tightening Torque for Piping

| Connection thread | Proper tightening torque |
|-------------------|--------------------------|
| M5                | 1.5 to 2 N·m             |

#### \* Reference

Fastening M5 thread fittings

Tighten manually, and then tighten a further quarter-turn using the fastening tool. If using miniature fittings, tighten manually, and then tighten a further quarter-turn using the fastening tool. If there are two gaskets, such as a universal elbow or universal tee, the final tightening should be doubled to a half-turn.

Note) Over-tightening of fittings may cause fracturing of the thread sections or deformation of the gaskets, leading to air leaks. If the fittings are under-tightened, the loosening of thread and air leaks may occur.

### Lubrication

#### Warning

##### 1. Lubrication

The cylinder has been lubricated for life at the factory and can be used without any further lubrication. However, in the event that it is additionally lubricated, be sure to use class 1 turbine oil (with no additive) ISO VG32. For details about lubricant manufacturers' brands, refer to the SMC website. Additionally, please contact SMC for details about class 2 turbine oil (with additives) ISO VG32.

Once lubricant is utilised within the system, since the original lubricant applied within the product during manufacturing will be washed away, please continue to supply lubrication to the system. Without continued lubrication, malfunctions could occur. If turbine oil is used, refer to the corresponding Material Safety Data Sheet (MSDS).

### Air Supply

#### Warning

##### 1. Use clean air.

Do not use compressed air containing chemicals, synthetic oils containing organic solvents, salts, or corrosive gases, etc., as these can cause damage or malfunctions.

#### Caution

- 1. Use the product within the range of specifications for fluid and ambient temperature.**
- 2. Install air filters.**  
Install air filters at the upstream side of the rotary joint. The filtration degree should be 5 µm or less.
- 3. Install an aftercooler, air dryer or water separator (drain catch), etc.**  
Air containing excessive drainage can cause malfunction of valves and other pneumatic equipment. To prevent this, install an aftercooler, air dryer or water separator, etc.  
Refer to the website [www.smc.eu](http://www.smc.eu) for further details on compressed air quality.

### Operating Environment

#### Warning

- 1. Do not use in environments where there is a danger of corrosion.**  
Refer to the construction drawings regarding rotary joint materials.
- 2. Do not use in dusty locations or where water, oil, etc. will splash on the equipment.**

### Maintenance

#### Warning

- 1. During maintenance, do not perform any disassembly or assembly whilst the air supply is connected.**

#### Caution

- 1. Drain flushing**  
Remove condensate from air filters at regular intervals.

## SMC Corporation

SMC CORPORATION  
Akihabara UDX 15F, 4-14-1, Sotokanda, Chiyoda-ku, Tokyo 101-0021, JAPAN  
Phone: 03-5207-8249 FAX: 03-5298-5362  
SMC CORPORATION All Rights Reserved

### European Marketing Centre (EMC)

Zuazobidea 14, 01015 Vitoria  
Tel: +34 945-184 100 Fax: +34 945-184 124  
URL <http://www.smc.eu>